







MATERIALS	
BODY	BRASS NICKEL PLATED
CONTACT	GOLD PLATED
INSULATOR	PTFE
GASKETS	RUBBER

HARDWARE			
			
CLAMP NUT	WASHER	GASKET	BRAID CLAMP
			
METAL SLEEVE	TEFLON SLEEVE	CONTACT	

ELECTRICAL & ENVIRONMENTAL CHARACTERISTICS

IMPEDANCE	50 OHMS
INSULATION RESISTANCE	5000 MΩ
OPERATING FREQUENCY	11 GHz
DIELECTRIC WITHSTANDING VOLTAGE	2500 Vrms
VSWR TYPICAL	1.30:1
INSERTION LOSS TYPICAL	.06 √ Freq. GHz
OPERATING TEMPERATURE	-65 to +165 C°
VOLTAGE RATING	1500 VOLTS
INTERFACE	MIL-STD-348
VIBRATION	MIL-STD-202 METHOD 204, CONDITION A
CORROSION	MIL-STD-202 METHOD 101, CONDITION B

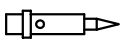
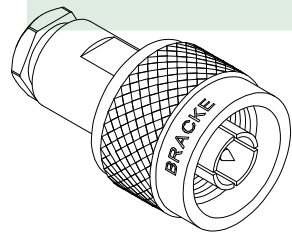

Scale 1:1

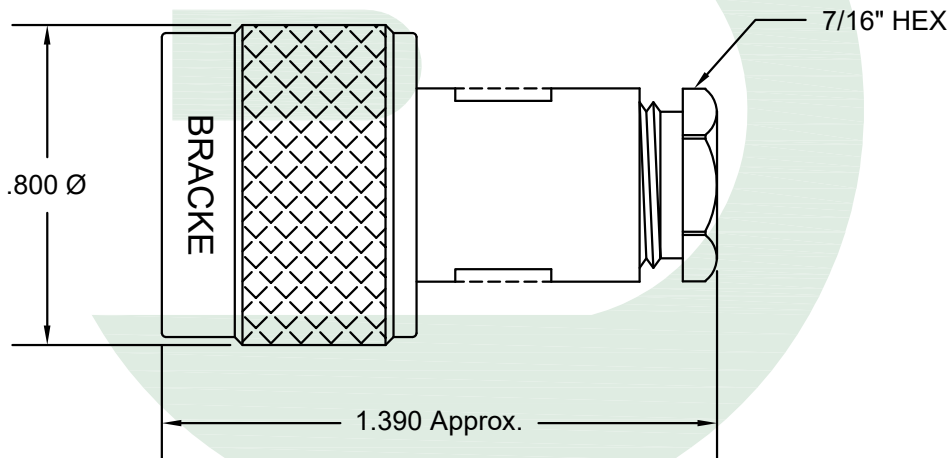

BRACKE
Bracke Manufacturing, LLC

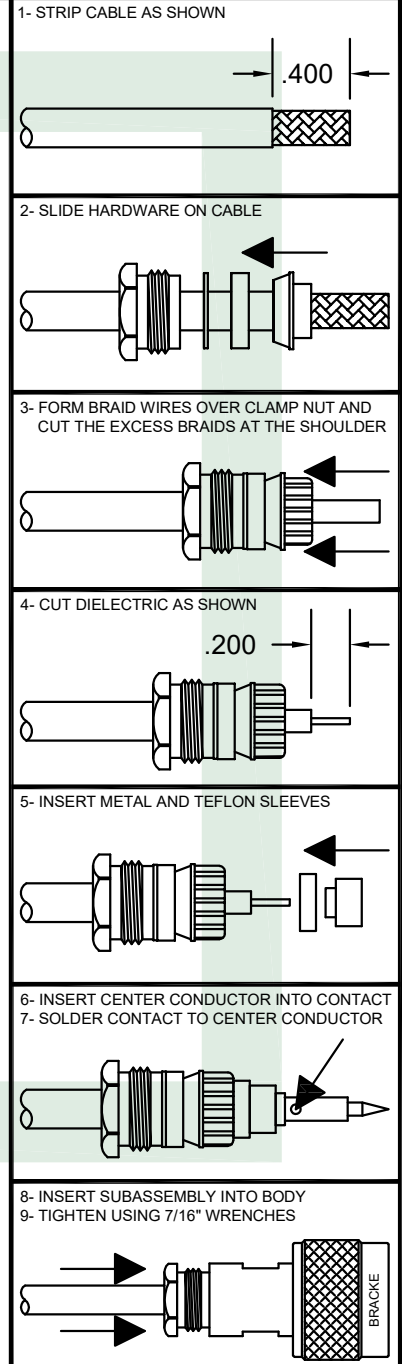

Bracke Manufacturing, LLC
PO Box 12319
Newport Beach, Ca 92658
Phone (949)756-1600 / Fax (949) 756-1601
sales@brackemfg.com / www.brackemfg.com

Part Number	
BM60268	
Produced By	Checked By
002	007

Description
N Male
Clamp Connector [RG55, RG58, RG141, RG142, RG223, RG400]

Notes

- Bracke Manufacturing, LLC reserves the right to change any specifications at any time in its sole discretion without notice.
- The depiction above was produced by and is the sole property of Bracke Manufacturing, LLC and may not be copied or reproduced in any manner without Bracke's prior written consent.

©2023 Bracke Manufacturing, LLC

CAGE / NAGE	
6LOW2	
Scale	Unit
2:1	Inches
Date	Revision
7/26/2023	A-01