

MATERIALS	
BODY	BRASS NICKEL PLATED
CONTACT	GOLD PLATED
INSULATOR	PTFE
ELECTRICAL & ENVIRONMENTAL CHARACTERISTICS	
IMPEDANCE	50 OHMS
INSULATION RESISTANCE	5000 MΩ
OPERATING FREQUENCY	18 GHz
DIELECTRIC WITHSTANDING VOLTAGE	1500 Vrms
VSWR TYPICAL	1.20:1
INSERTION LOSS TYPICAL	.06 $\sqrt{\text{Freq. GHz}}$
OPERATING TEMPERATURE	-65 to +165 C°
VOLTAGE RATING	500 VOLTS
INTERFACE	MIL-STD-348
VIBRATION	MIL-STD-202 METHOD 204, CONDITION A
CORROSION	MIL-STD-202 METHOD 101, CONDITION B

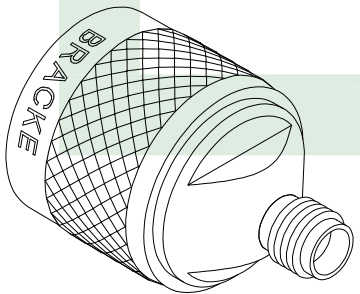

Scale 1.5:1

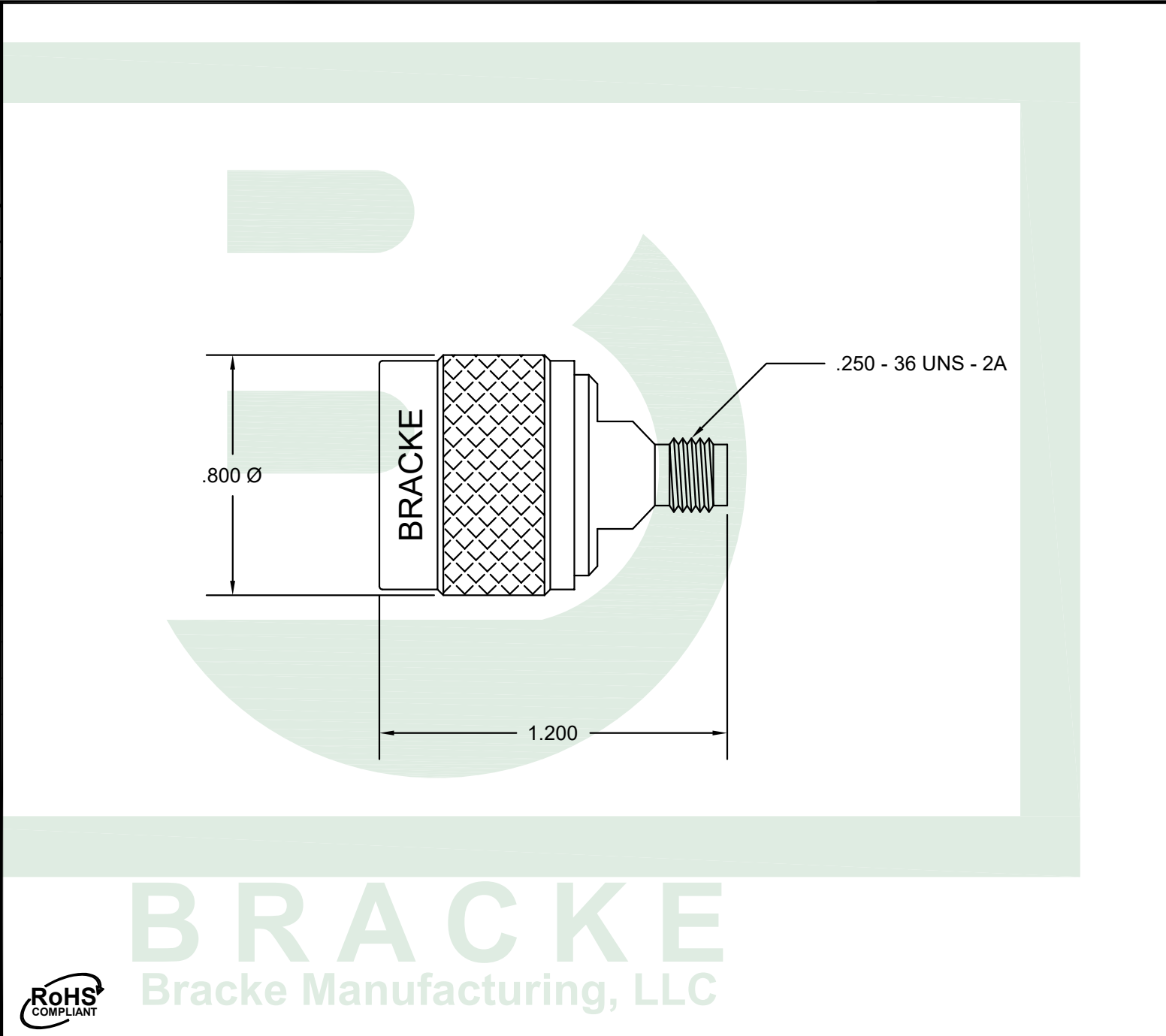

**BRACKE**  
Bracke Manufacturing, LLC



**Bracke Manufacturing, LLC**  
PO Box 12319  
Newport Beach, Ca 92658  
Phone (949)756-1600 / Fax (949) 756-1601  
sales@brackemfg.com / www.brackemfg.com

Part Number	
<b>BM50025</b>	
Produced By	Checked By
002	013

Description	
<b>N Male to SMA Female [Adapter]</b>	
Notes	
<ul style="list-style-type: none"> <li>Bracke Manufacturing, LLC reserves the right to change any specifications at any time in its sole discretion without notice.</li> <li>The depiction above was produced by and is the sole property of Bracke Manufacturing, LLC and may not be copied or reproduced in any manner without Bracke's prior written consent.</li> </ul>	
©2023 Bracke Manufacturing, LLC	

CAGE / NAGE	
6LOW2	
Scale	Unit
2:1	Inches
Date	Revision
4/26/2023	A-01