

DATASHEET APMSYN22 Specification v1.12

Ultra-Agile Frequency Synthesizer from 100 kHz to 22 GHz



Document size:

1 title page
11 content pages

DEFINITIONS

- The specifications in the following pages describe the warranted performance of the instrument for 23 ± 5 °C after a 30-minute warm-up period (unless otherwise stated).

Min/Max: Parameter range that is guaranteed by product design, and/or production tested. Warranted performance specifications include guard-bands to account for the expected statistical performance distribution, measurement uncertainties, and changes in performance due to environmental conditions.

Typical: Expected mean values, not warranted performance.

INTRODUCTION

- The APMSYN22 is a compact-size frequency synthesizer for the generation of accurate and stable frequency signal in both CW and pulse form, covering a frequency range of 100 kHz to 22 GHz, with a fast-switching time of 5 us, the output power of -40 to 25 dBm depending on the frequency. The phase noise at 1 GHz and 20 kHz offset is -132 dBc/Hz, and the subharmonics and spurious lower than -55 dBc. The frequency setting resolution is 10 mHz and for the power 0.5 dB.

The synthesizer is excellently shielded and in a very compact flange-mountable form of 134 x 95 x 25 mm, weighs lighter than 0.5 kg, and consumes barely 17 W and therefore passively cooled. It features ETHERNET communication port for local and remote connection to a PC for control over GUI software or SCPI commands.

The module features external reference support of 100 MHz and 1 GHz. Multiple units can be connected, with one unit acting as the master and the others as slaves, to implement multi-channel PHASE-COHERENT sources. The Master reference frequency of 1 GHz is generated once in the master unit and looped through all the slave units. The phase coherence reached is about +/- 0.5 degree over 10 hours when all the channels are set to 5 GHz.

The product is suitable for many applications: as system clock source, in the multi-channel phase-coherent configurations for radar, beamforming, quantum computing, etc. The feature combination of phase coherence and fast switching allows also for applications in Electronic Warfare field.

SPECIFICATIONS



PARAMETER	MIN	TYPICAL	MAX	NOTE
Frequency range	100 kHz		22 GHz	
Resolution		0.01 Hz		
Phase resolution		0.1 deg		
Switching speed in sweep mode		500 μ s 5 μ s	10 μ s	Option FS
SSB Phase noise at 1 GHz				See also plots
at 10 Hz from carrier		-87 dBc/Hz		
at 1 kHz from carrier		-122 dBc/Hz		
at 20 kHz from carrier		-132 dBc/Hz		
at 10 MHz from carrier		-150 dBc/Hz		
Spectral purity				
Output harmonics				$P_{out} = 10$ dBm
<4.0 GHz		-15 dBc		
4.0 - 12 GHz		-30 dBc		
>12.0 GHz		-50 dBc		
Sub-harmonics				$P_{out} = 10$ dBm
< 11.0 GHz		-80 dBc	-70 dBc	
11.0 – 20.0 GHz		-70 dBc	-60 dBc	
>20.0 GHz		-65 dBc		
Non-harmonic spurious (>10 kHz offset)		-65dBc	-55dBc	
Power level				See also plots
Range				
0.1 – 1 GHz	-20 dBm		+25 dBm	
1-10 GHz	-30 dBm		+23 dBm	
10-18 GHz	-30 dBm		+22 dBm	
18-20 GHz	-40 dBm		+18 dBm	
>20 GHz	-40 dBm		+16 dBm	
Resolution		0.5 dB		
Level uncertainty		± 1.5 dB		
Output impedance		50 Ω		
VSWR		1.7	2.0	
Reference frequency input	100 MHz, 1 GHz			
Reference input level				
100 MHz	-3 dBm		+5 dBm	
1 GHz	-5 dBm		+5 dBm	
Lock Range			+/- 10 ppm	
Reference input impedance		50 Ω		
Internal reference frequency output		1 GHz		
Power		0 \pm 3 dBm		calibrated at 23 \pm 3 $^{\circ}$ C
Calibrated accuracy of int. reference		± 30 ppb		calibrated at 23 \pm 3 $^{\circ}$ C
Temperature stability (0 to 50 $^{\circ}$ C)			± 100 ppb	

Aging 1 st year		0.5 ppm		
Aging per day			5 ppb	After 30 days operation
Warm-Up time		5 min		
RF out reverse power protection				
DC voltage			7 V	
RF power			23 dBm	
Multi-Channel Configurability				
Recommended configuration	One master and multiple slave units are synchronized by 1 GHz reference in daisy chain. If used as slaves, the units don't need to have internal frequency references: Option NOXO.			
Relative phase stability among the multi-channels (phase coherence)		15 mrad		@5 GHz over 5 hours

Sweeping Capability

PARAMETER	MIN	TYPICAL	MAX	NOTE
Frequency / List sweep				
Sweep type: linear, logarithmic, random				
Step time	500 μ s 5 μ s		200 s	Option FS
Timing resolution		5 ns		
Timing accuracy per point		20 ns		
Generalized list sweep				
Allows for individual setting of frequency, step-time, and off-time for each point				

Modulation Capabilities

PARAMETER	MIN	TYPICAL	MAX	NOTE
Pulse modulation				
On/off ratio				
< 10 GHz		80 dB		
> 10 GHz		60 dB		
Repetition frequency	DC		10 MHz	
Pulse width	30 ns		20 s	
Pulse rise/fall time		9 ns		
Pulse trainlength (pulses)	2		4192	
Video crosstalk		-40 dB		
Modulation source		Int. / ext.		Trigger port can be reconfigured as external modulation port.
External input threshold	0.85 V	0.9 V	0.95 V	TTL compatible
External input voltage range	-0.5 V		+5.5 V	TTL compatible
External input hysteresis		60 mV		
Delay (to RF)		20 ns	40 ns	

Trigger (TRIG IN/OUT)

PARAMETER	MIN	TYPICAL	MAX	NOTE
Trigger Types				Continuous, single (point), gated, gated direction
Trigger Source				external, Ethernet
Trigger Modes				Continuous free run, trigger and run, reset and run
Trigger uncertainty		5 μ s		
External Trigger delay	50 μ s		40 s	
External Delay Resolution		15 ns		
Trigger Modulo	1		255	Execute only on Nth trigger event
Trigger Polarity		rising, falling		
External trigger input threshold	0.85 V	0.9 V	0.95 V	TTL compatible
External trigger input voltage range	-0.5 V		+5.5 V	TTL compatible
External trigger input hysteresis		60 mV		

PERFORMANCE CURVES

Typical Maximum Output Power

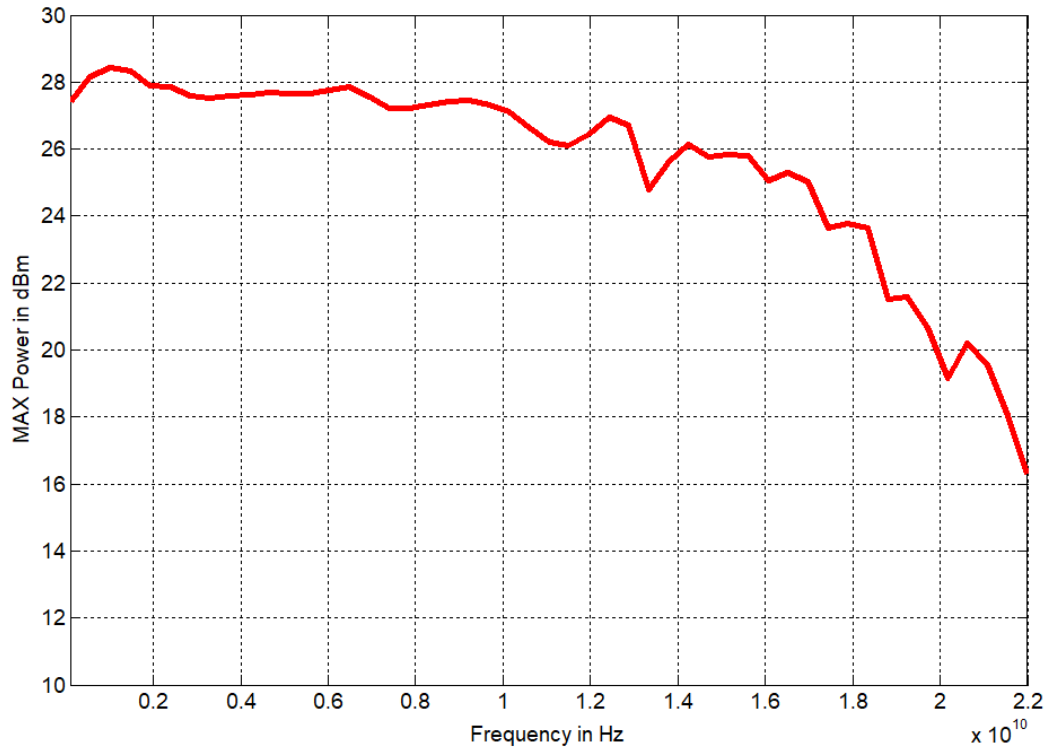

Harmonics at 10 dBm Output

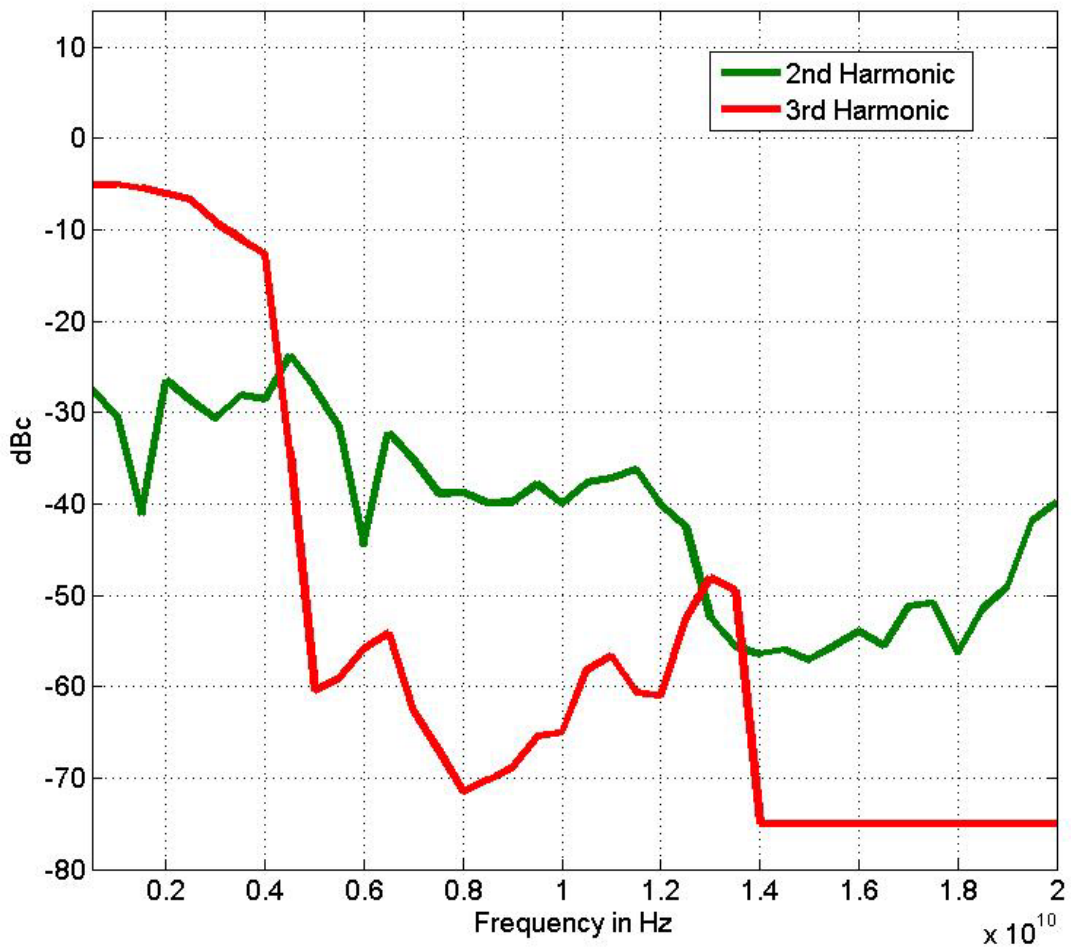

Phase Noise Performance

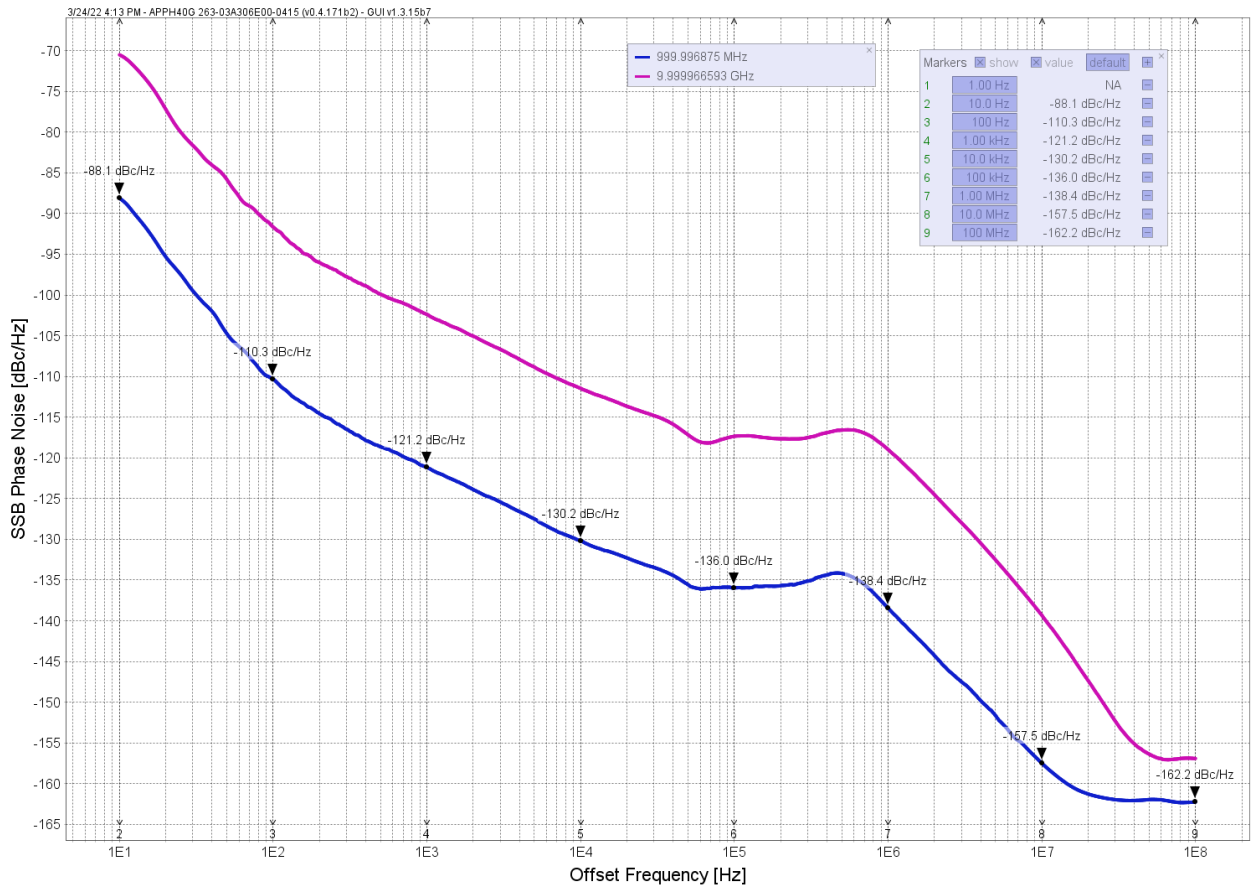

Wideband Spectrum at 21 GHz output

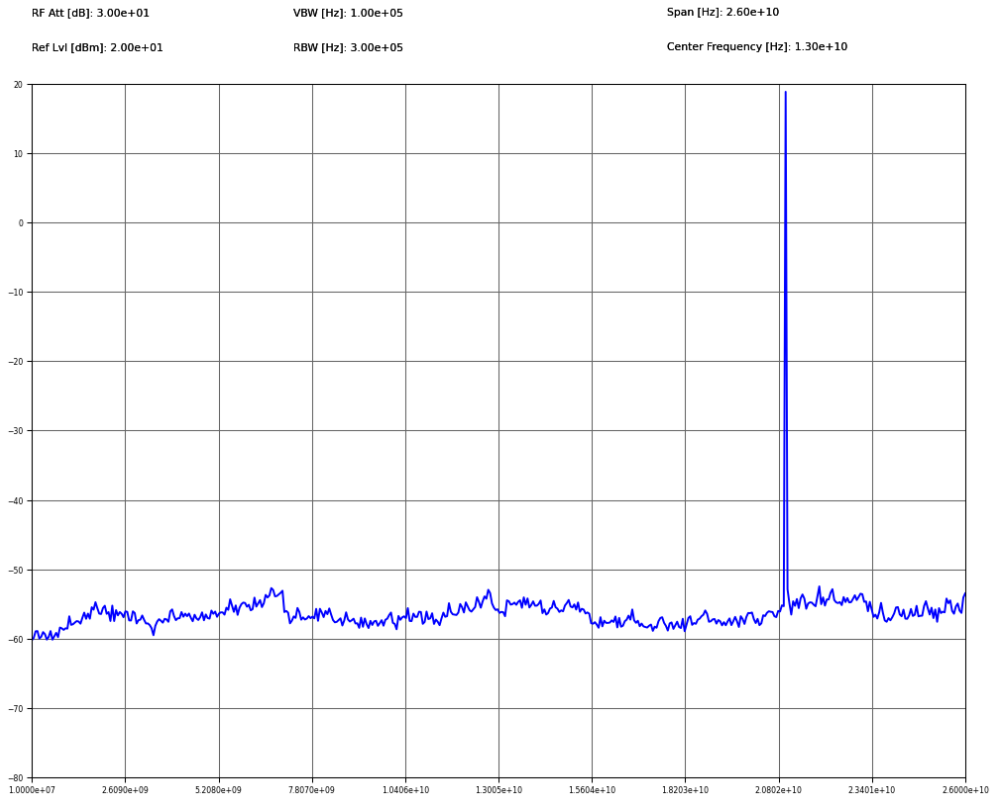

MECHANICAL SPECIFICATIONS

Dimensions & Weight

Dimensions / Weight	
Including connectors	W x L x H = 134 x 95 x 24 mm / 0.45 kg

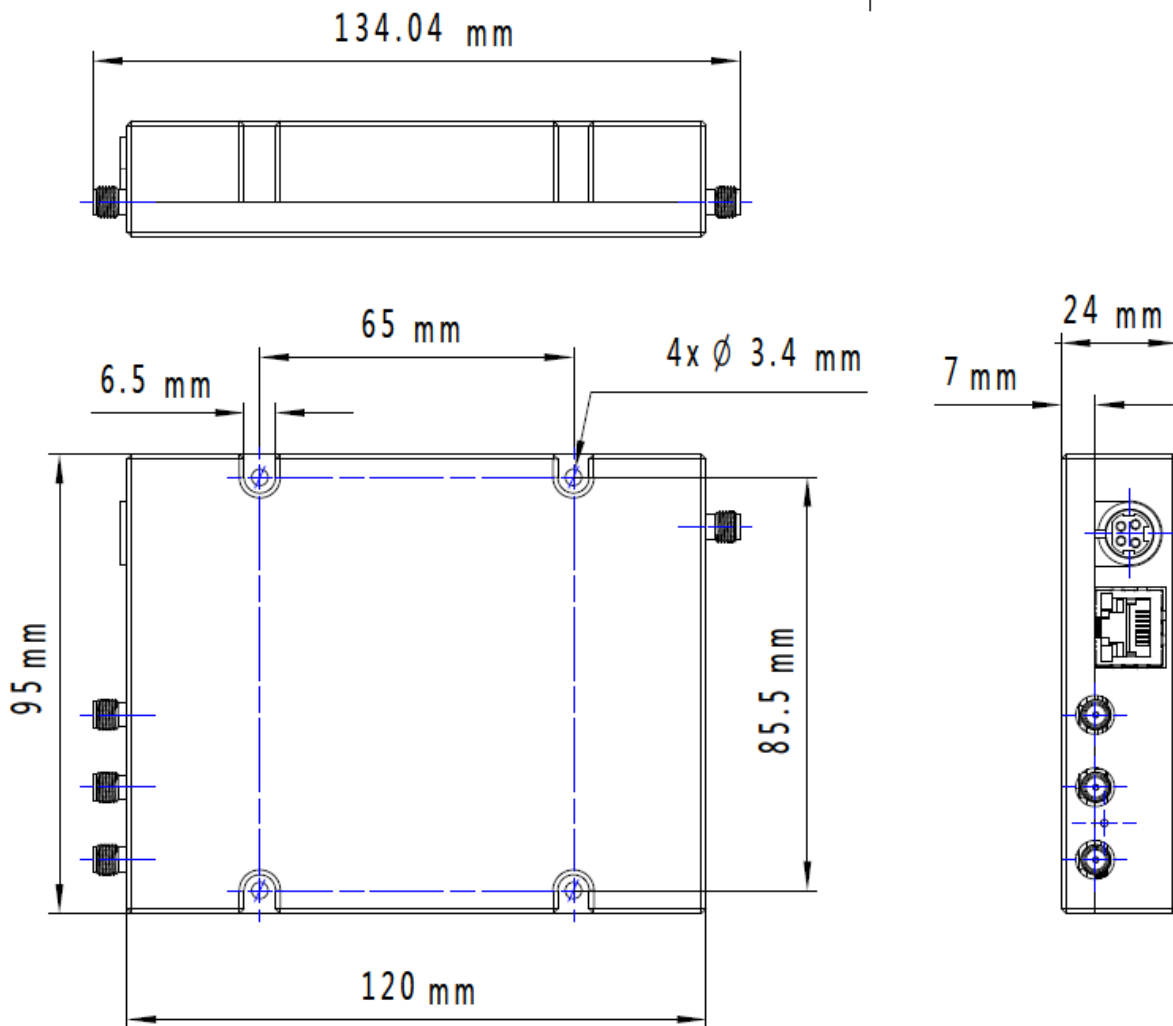

Installation Instructions

The module relies on passive cooling. It is mandatory to mount the device on a heatsinking surface. Make sure the synthesizer operates under the conditions specified in this document. specs in this datasheet. Otherwise, the thermal protection will turn off the RF output.

CONNECTORS

Front panel

LABEL	TYPE	DESCRIPTION
PWR	LED	Power ON/OFF indicator
REM	LED	Remote connection status indicator
RF	LED	RF output ON/OFF indicator
RF OUT	SMA	RF output



Rear panel

LABEL	TYPE	DESCRIPTION
DC IN	KPJX-4S (Kycon)	DC input (Pin 1/4: +24 V; Pin 2/3: GND)
ETH	RJ-45	Ethernet port
REF IN	SMA	Reference Signal input
TRIG	SMA	Trigger Signal input
RST	Button	Reset Button
REF OUT	SMA	Reference Signal output



Reset Functionality

The reset functionality of the device can be used if the device has a wrong configured IP address and cannot be found in the local area network anymore. While pressing the reset button (>2 s), the device will be reconfigured to auto IP addressing mode (DHCP/Zero-conf) and restarts itself. After the device is up and running again, it gets a new IP address and can be discovered by the AnaPico Signal Generator UI.

ORDERING INFORMATION

HOST MODEL	PRODUCT	DESCRIPTION
APMSYN22	APMSYN22	22 GHz wideband frequency synthesizer module
APMSYN22	Option FS	Fast switching option
APMSYN22	Option NOXO	No internal reference
APMSYN22	Option DATA	Commercial Calibration Certificate with test data
APMSYN22	Option WE	One year warranty extension (standard: 2 years)
APMSYN22	Option ReCal	Recalibration with certificate (recommended: 2 years interval)

GENERAL CHARACTERISTICS

Remote programming interfaces

Ethernet interface

Control language: SCPI Version 1999.0

Power requirements: 24±6 VDC; 17 W maximum

Mains adapter supplied: 100-240 VAC in / 24 V, 2.7 A DC out

Storage temperature range: – 40 to 70 °C

Operating temperature range: 0 to 45 °C

Operating and storage altitude: up to 15,000 feet



Safety/EMC complies with applicable Safety and EMC regulations and directives.

Recommended calibration cycle: 24 months



Document History

Version	Date	Author	Notes
V10	2021-11-10	jk	first release
V11	2022-04-25	ah	Parameter added
V12	2022-05-23	yg	Added intro, multi-channel configurability and phase coherence specs

AnaPico of Switzerland

Europa-Strasse 9
8152 Glattbrugg
Switzerland

Phone +41 44 440 00 50
Email sales@anapico.com

www.anapico.com
www.anapico.com/downloads/

NOTES