

EM-4U-K3851

Barebone – Industrial solution

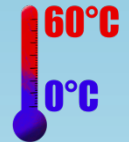

SPECIFICATION

Chassis	448,37(L)x482(W)x177mm(H) (with handles), 426(L)x482(W)x177mm(H) (without handles), Weight ~14kg
	Color: Black, from 20 pcs could be customized
	Material: zinc steel /aluminium
	Mounting options – Rack mounting
	Customizable front panel (optional - UV print / laser marking logo
Drive bays and internal positions	2x GPUs (optional)
	Noctua CPU Cooler – low height
	MB: 243,8 x 304,8 mm, ATX (Kontron K3851)
	PSU: FSP850-50AEC / FSP1200-57ASB
Front panel	Power button with LED backlight
	2x USB 3.x
Rear panel	6x USB 3.x, 1x USB-c, Audio in/out, COM RS232
	3x LAN, 4x Display port V1x4a up to 8K

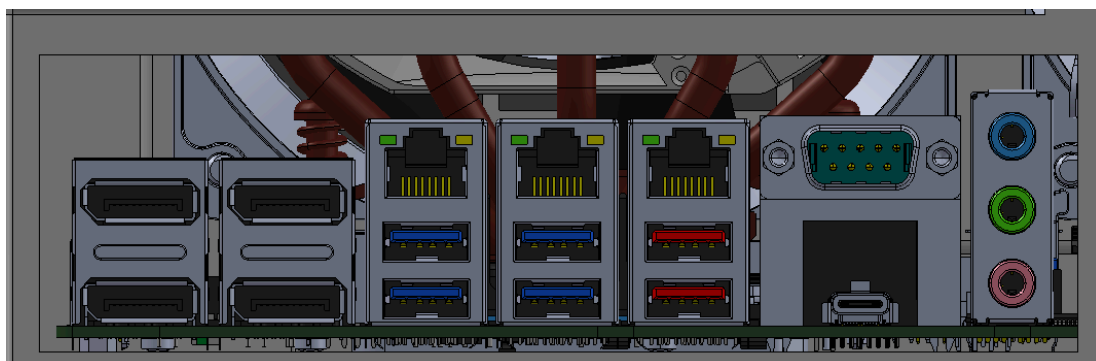
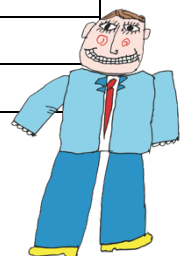

ALL PRODUCT SPECIFICATIONS ARE SUBJECT TO CHANGE WITHOUT NOTICE.

EMKO IPC S.R.O., ŘÍPská 11F, 627 00 BRNO – SLATINA, CZECH REPUBLIC

TEL.: (+420) 515 917 670, WWW.EMKOIPC.COM, INFO@EMKOIPC.COM





EM-4U-K385 1

<p>System Chipset / CPU+Cooler</p>	<p>Socket LGA 1700, R680E</p> <p>Intel Core i7-14700:</p> <ul style="list-style-type: none"> - Total cores: 20 - Max. Turbo Frequency: 5.4 GHz - Max. TDP 125W (cTDP flexible) - Bios: AMI Aptio 5.x (UEFI) BIOS adapted by Kontron <p>CPU Cooler NH-D12L:</p> <ul style="list-style-type: none"> - Low height (145mm) dual tower cooling system for 4U Chassis
<p>Memory</p>	<p>DRAM - 16 GB, DDR5 U-DIMM, 4800 MHz, normal temperature (0°C to 85°C), Industrial fixed BOM</p> <p>General information below:</p> <p>Sockets:</p> <p>1x DIMM per channel = max. DDR5-4400 2x DIMM per channel (single rank) = max. DDR5-4000 2x DIMM per channel (dual rank) = max. DDR5-3600</p> <p>Technology:</p> <p>Dual Channel unbuffered DDR5 4800MHz-(supports ECC)</p>
<p>Storage</p>	<p>SSD:</p> <p>1x 256GB M.2 2280 3D TLC PCIe Gen3x4 normal temperature (0°C to 70°C), Industrial fixed BOM 1x 1 TB M.2 2280 3D TLC PCIe Gen3x4 normal temperature (0°C to 70°C), Industrial fixed BOM</p> <p>General information below:</p> <ul style="list-style-type: none"> - 3K P/E cycle, 112-layer 3D NAND - Ultra fast PCIe Gen3x4 interface - LDPC ECC Raid Engine, SLC Cache - E2E Data Path Protection, AES 256-bit encryption - HMB (Host Memory Buffer)
<p>Ethernet</p>	<p>Interface – 3x RJ-45</p> <ul style="list-style-type: none"> - 1x 1GbE LAN Intel® i219LM - 2x 2,5GbE LAN Intel® i225LM + support Wake-on-LAN (WoL)

ALL PRODUCT SPECIFICATIONS ARE SUBJECT TO CHANGE WITHOUT NOTICE.

EMKO IPC S.R.O., ŘÍPSKÁ 11F, 627 00 BRNO – SLATINA, CZECH REPUBLIC

TEL.: (+420) 515 917 670, WWW.EMKOIPC.COM, INFO@EMKOIPC.COM





Chassis dimensions (mm):

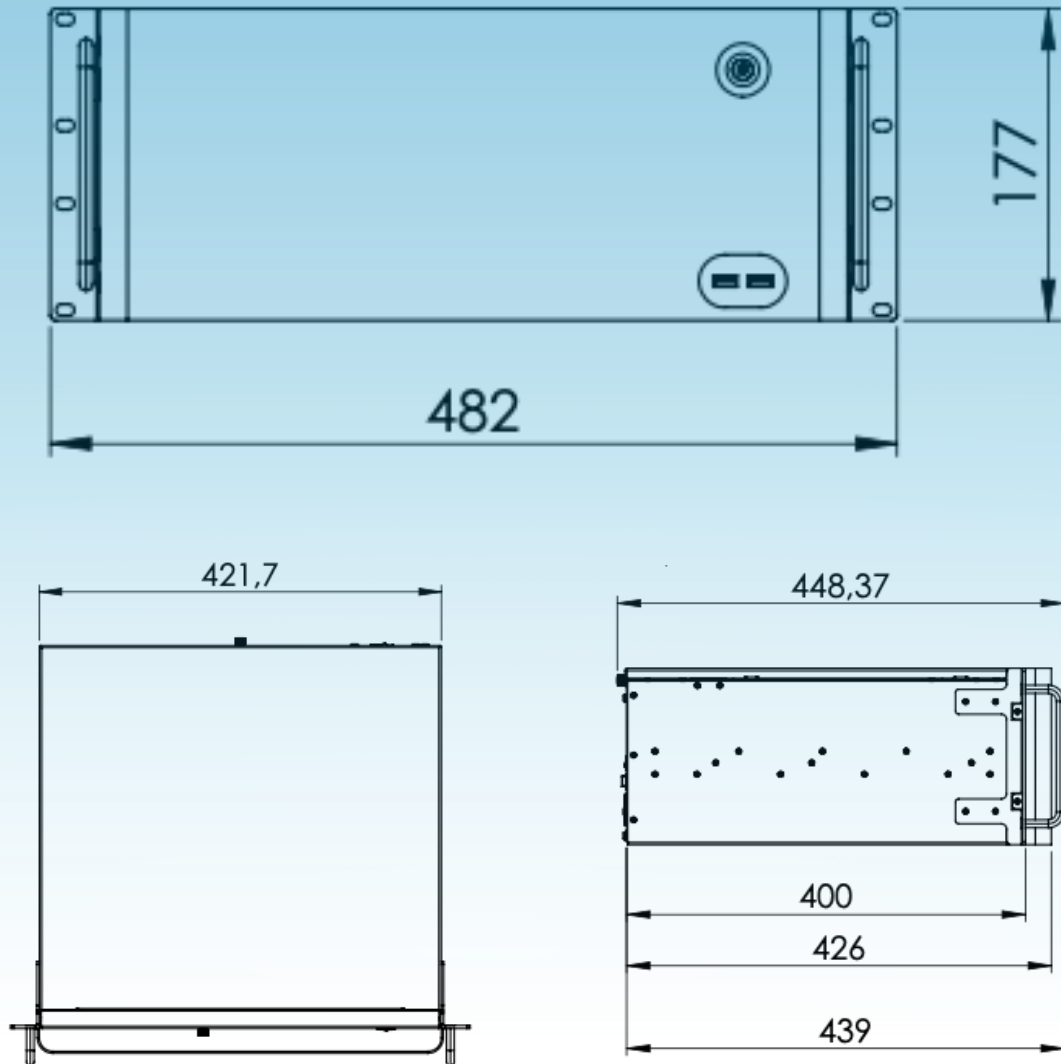

ALL PRODUCT SPECIFICATIONS ARE SUBJECT TO CHANGE WITHOUT NOTICE.

EMKO IPC S.R.O., ŘÍPSKÁ 11F, 627 00 BRNO – SLATINA, CZECH REPUBLIC

TEL.: (+420) 515 917 670, WWW.EMKOIPC.COM, INFO@EMKOIPC.COM





kontron

KONTRON K3851-R

INDUSTRIAL MOTHERBOARD

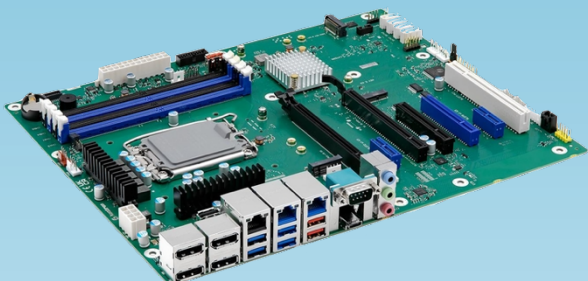

Supported Memory	Up to 128 GB, DDR5 U-DIMM
CPU options	Intel® Core™ i9/i7/i5/i3 (12th/13th/14th Gen) processor series
	Intel® Pentium®/Intel® Celeron® processor series
	Socket LGA1700, max 65W TDP
	Chipset R680E
I/O Interface	4x Displayport V1x4a up to 8K
	1x USB-C, 4x USB 3.2 Gen1, 2x USB 3.2 Gen2
	4x SATA III 6G, incl. RAID, 1x COM port (+ 3 optional)
	2x M.2 2230/2242/2280 (Key-M, PCIe/NVME SSD modules) + NVME RAID support
	1x M.2 2230 Key-E (WLAN/Bluetooth modules, incl. CNVi)
	PCIe x16 Gen5
	1x 1GbE LAN + 2x 2,5GbE LAN
	ATX (Multirail) + 8-pin socket (12 V for CPU)
Product features	HW Watchdog, System Guard / cTDP, Silent Fan
	OS Support – Windows 10, Windows 11, Linux-64
	Logo Boot Option, TPM V2.0



ALL PRODUCT SPECIFICATIONS ARE SUBJECT TO CHANGE WITHOUT NOTICE.

EMKO IPC S.R.O., ŘÍPSKÁ 11F, 627 00 BRNO – SLATINA, CZECH REPUBLIC

TEL.: (+420) 515 917 670, WWW.EMKOIPC.COM, INFO@EMKOIPC.COM

